

types overview
FM-0250

Sesam

Frank Sitzmöbel GmbH - Grafenheider Straße 20 - D-33729 Bielefeld
Tel +49 (0) 521 / 164 60-0 Fax -19

www.frank-sitzmoebel.de | info@frank-sitzmoebel.de

SESAM



Model description

Design: Georg Appeltshauser

Frame: Back/armrest is a foam-encased welded metal frame. Seat frame made of special high quality welded steel. Footrests slats and mechanical linkage made from welded and riveted steel. All joints are provided with bearing bushes.

Springs: Elastic straps with tight cross braiding.

Upholstery: Seat cushion made up of several layers. Seat support padding made of Bultex foam, volume weight 50 kg/m³ (RAL 37). Comfort padding in seat cushion made of 300 g polyether wadding. Back cushion and head cushion made up of compartments filled with feathers and foam rods. Back and armrest made of moulded polyurethane foam with volume weight of 50 kg/m³. Footrest padded with Bultex foam.

Function: Armchairs and sofas can be supplied with or without footrest slats. The range with footrest function has a built in metal support for

the head- and armrest cushion. It is possible to have the headrest function for the sofa range without footrest support with an extra charge.

Foot frame: Tubular steel construction, coated in black. The footrest frame can be dismantled in two parts for transportation purposes.

Feet: Natural polished cast aluminium with PE glides.

Cover processing: Soft fabric and leather processing. Cushion and body covers removable. Edges with ornamental fell seam.

Seating comfort: We achieve extremely comfortable seating due to our intensive development work and the use of high quality, multi-layer material compositions.

Transport: In order to make it easier to transport the functional sofa components, these are always delivered in 2 parts. The assembly is possible on site without any complications.

SESAM

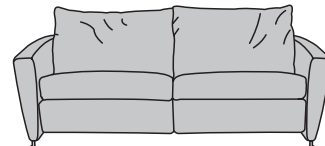
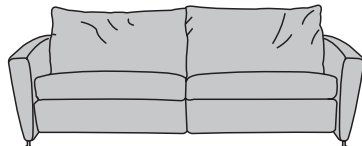

MODEL	SO 208 FM-0250/53	SO 208 FM-0250/63	SO 188 FM-0250/23	SO 188 FM-0250/33
	Sofa with functions and with 2 pcs Armrest cushion	Sofa w/o function, w/o Koki metal support and w/o Armrest cushion	Sofa with functions and with 2 pcs Armrest cushion	Sofa w/o function, w/o Koki metal support and w/o Armrest cushion
SIZES IN CM				
Width	208	208	188	188
Depth	91/150	91	91/150	91
Height	83/100	83	83/100	83
Special height	---	---	---	---
Seating depth	51/110	51	51/110	51
Seating height	44	44	44	44
Special Seating height	---	---	---	---
Armrest height	57	57	57	57
FABRIC/LEATHER				
Front raw edge, rm/140	11,20	9,80	10,70	9,30
Front selvedge, rm/140	11,20	9,80	10,70	9,30
Leather sqm	16,60	15,40	15,40	14,10
Customer's own fabric*				
Customer's own leather* (*See page 6)				
Fabric Price Group** 05 (**See page 99)				
07				
12				
14				
15				
Microsede Col Cht. 16				
19				
Leather Price Group F				
A/O				
K				
N				
Requested Leather col. W***				
*** Description p. 95				

ORDER INFORMATION

Release lever for the mechanism available in special steel (standard) or black lacquer

Mechanical design:

KTL coated black

Koki metal support:

Standard: silver or special design: black lacquered

Feet:

Standard: - natural anodised aluminium

- black epoxy-coated aluminium

additional price per component:

Special design: - straight feet, natural anodised aluminium

- black epoxy-coated aluminium

additional price per component:

Components w/o function:

Special Design: with Koki metal support silver or black

additional price per Koki:

Special sizes are not available.

Feet and metal supporting are not available in special colours.

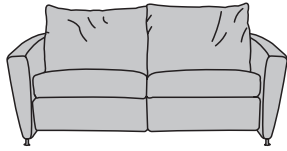

SO 168 FM-0250/02 Sofa with functions and with 2 pcs Armrest cushion	SO 168 FM-0250/12 Sofa w/o function, w/o Koki metal support and w/o Armrest cushion	SE 083 FM-0250/01 Armchair with functions and with 1 pcs Armrest cushion	SE 083 FM-0250/11 Armchair w/o function, w/o Koki metal support and w/o Armrest cus- hion	ATKI/KOKI FM-0250/98 Armrest cushion/ headrest cus- hion for sofa 1 pc	ATKI/KOKI FM-0250/96 Armrest cushion (ATKI) headrest cus- hion for arm- chair 1 pc
168	168	83	83	50	40
91/150	91	91/150	91	45	35
83/100	83	83/100	83	---	---
---	---	---	---	---	---
51/110	51	53/112	53	---	---
44	44	44	44	---	---
---	---	---	---	---	---
57	57	57	57	---	---
9,40	8,00	5,00	4,30	0,70	0,70
9,50	8,10	5,00	4,30	0,70	0,70
13,80	12,90	7,50	7,30	1,10	0,80
05					
07					
12					
14					
15					
16					
19					
F					
A/O					
K					
N					
W***					

All legs come with slot-in glides for carpet and parquet floors.

Cushion padding

Back cushion

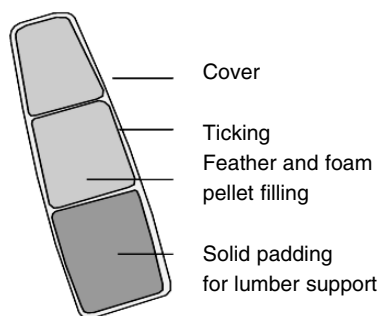

Seam types

Fell seam

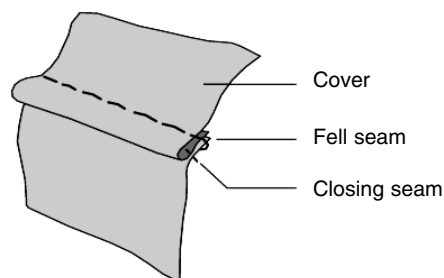

We do not process velours.

Seat cushion

Support padding made of Comfort Bultex

25 mm of soft padding

Comfort padding wrapped in cloth

Elastic padding made of Comfort bultex

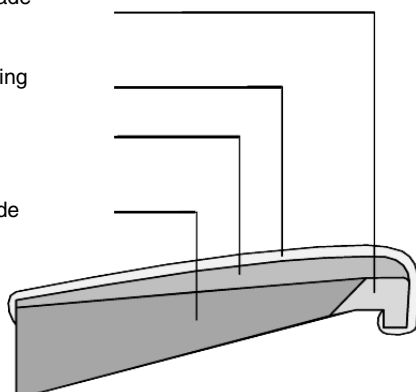

We use comfort Bultex in different strengths and volume weight for our high quality padding. They exceed RAL requirements by far.

Environmental balance

Frame: The steel construction is untreated.

Padding: The polyurethane foam used is produced with water vapour and is CFC-free.

Adhesives: Most of the adhesives are water-based products. For complex bonds, we now use adhesives containing reduced amounts of solvent.

Mechanical design: The mechanism is screwed together and can be separated. It has a solvent-free KTL varnish.

Leather covers: The dyes in our shagreen are free from solvent on completion of the production process. Since 1985, FSM has processed leather with reduced chrome content which is free from solvents. This exceeds German environmental standards.