



types overview
FM-0259

Decus

Frank Sitzmöbel GmbH - Grafenheider Straße 20 - D-33729 Bielefeld
Tel +49 (0) 521 / 164 60-0 Fax -19

www.frank-sitzmoebel.de | info@frank-sitzmoebel.de

Decus



Model description

Design: Georg Appeltshauser

Frame: Sides and back made from wooden material. Seating frame made from high-quality, special steel profile KTL varnished and welded; footrest section and mechanism struts made from steel, welded and riveted. Bearing bushes at each joint.

Springs: elastic straps with tight cross braiding.

Upholstery: seat in multi-layer construction: Seat support padding made from Bultex foam with volume weight in the edge area of 68 and in the seating area of 43. The comfort upholstery is made from VW 35 cold foam with a visco-elastic interlayer and a high-quality padding with cushioned compartments with VW of 40 made from crimped, siliconised hollow fibres and air cell rods (mixture of 10 % fibres and 90 % rods). Back cushion/headrest as cushioned compartments with a mixture of rods and synthetic PES fibres. Back and armrest section in multi-layer Bultex foam construction and highlighted with a softly wadded, comfort padding. Back is additionally furnished with a high-quality chambered padding with 28 VW made from crimped, siliconised hollow fibres and air cell rods (mixture of 20 % fibres and 80 % rods).

Function: Sofas are available with function or only with the high-back function without the metal bracket and footrest. For relaxing, use the lever between the seat and arm section to swing out the foot section. By folding the back upwards, the height is

raised by 17 cm to make a high-back chair. A height-adjustable fold-down bar is integrated into the back to convert the head and back cushions into a support system.

Base: Tubular steel construction available in black lacquer or stainless steel

Glidors: FSM "**Super Glider slippery**" inserts made from high-tech POM synthetic for soft-rough surfaces such as carpets, sisal, needle felting, cork, cement or metal. FSM "**Stop Glider anti-slip**" (pre-assembled ex factory) insert made from slip-resistant elastomer for all smooth, slippery surfaces such as marble, ceramic tiles, natural stone or wooden floors. FSM "**Soft Glider**" insert made from downy-soft felt for parquet floors, timber floorboards, laminates, marble or tiles.

Cover processing: light cushiony and wrinkled fabric and leather processing. Cushion covers and body covers cannot be removed. Edges have decorative fell seams.

Seating comfort: We achieve extremely comfortable seating due to our extensive development work and the use of high-quality, multi-layer material compositions.

Transport: The sofa components are generally in two parts to facilitate transport. On-site assembly is very easily done.

Safety: Please avoid applying too much weight to the footrest or backrest while the chair is in the relax position. The footrest is designed for supporting the feet and is suitable for weights up to 30 kg.

Decus

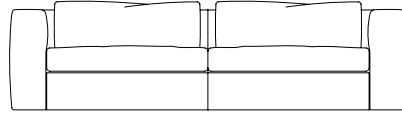

Armrest width 23 cm standard, optionally 21 cm

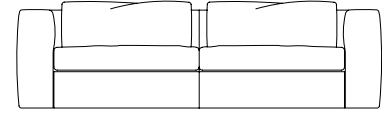

Armrest width 23 cm standard, optionally 21 cm

MODEL	SO 246 (242) Sofa FM-0259/03 with full function (footrest, high back, headrest bracket)	SO 246 (242) Sofa FM-0259/13 only with high-back function (higher back, without footrest and without headrest bracket)	SO 226 (222) Sofa FM-0259/53 with full function (footrest, high back, headrest bracket)	SO 226 (222) Sofa FM-0259/63 only with high-back function (higher back, without footrest and without headrest bracket)
-------	---	--	---	--

SIZES IN CM				
(*Standard) Width	246*/242	246*/242	226*/222	226*/222
Depth	97/154	97/154	97/154	97/154
Height	70/87	70/87	70/87	70/87
Special height				
Seating depth	58/116	58/116	58/116	58/116
Seating height	46	46	46	46
Special Seating height				
Armrest height	68	68	68	68

FABRIC/LEATHER	Armrest width				Armrest width			
	21 cm	23 cm	21 cm	23 cm	21 cm	23 cm	21 cm	23 cm
Front raw edge, rm/140	13,80	14,30	13,10	13,60	12,80	14,20	11,80	13,30
Front selvedge, rm/140	13,80	14,30	13,10	13,60	12,80	14,20	11,80	13,30
Leather sqm	23,60	23,90	21,70	22,00	22,10	22,30	20,30	20,50

Customer's own fabric*				
Customer's own leather* (*See page 6)				
Fabric Price Group 05 (**See page 99)				
07				
12				
14				
15				
Microsede Col Cht. 16				
19				
Leather Price Group F				
A/O				
K				
N				
Requested Leather col. W***				

*** Description p. 95

ORDER INFORMATION

Release lever for the mechanism available in special steel (standard) or black lacquer

Footrest mechanism:

Standard: KTL coated black
 Special design: Brushed special steel additional price per component:

Headrest bracket:

Standard: Brushed special steel
 Special design: Polished high gloss special steel additional price per component:
 (chrome look)

Components only with high-back function:

the loose sofa cushion is worked up without loops on the back
 Special design: with back bracket and loops additional price per component:

Armrest:

Available in two different widths (21 cm and 23 cm). Please note the standard width stated for each component!

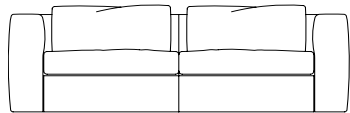

Armrest width 21 cm standard, optionally 23 cm

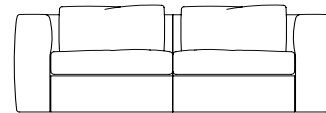

Armrest width 21 cm standard, optionally 23 cm

SO 202 (206) Sofa FM-0259/23 with full function (footrest, high back, headrest bracket)		SO 202 (206) Sofa FM-0259/33 only with high-back function (higher back, without footrest and without headrest bracket)		SO 182 (186) Sofa FM-0259/02 with full function (footrest, high back, headrest bracket)		SO 182 (186) Sofa FM-0259/12 only with high-back function (higher back, without footrest and without headrest bracket)	
206/202*		206/202*		186/182*		186/182*	
97/154		97/154		97/154		97/154	
70/87		70/87		70/87		70/87	
58/116		58/116		58/116		58/116	
46		46		46		46	
68		68		68		68	
Armrest width				Armrest width			
21 cm	23 cm	21 cm	23 cm	21 cm	23 cm	21 cm	23 cm
11,80	12,30	10,80	11,30	10,50	11,70	9,50	10,70
11,80	12,30	10,80	11,30	10,50	11,70	9,50	10,70
20,60	20,80	18,90	19,10	19,00	19,20	17,60	17,80
05							
07							
12							
14							
15							
16							
19							
F							
A/O							
K							
N							
W***							

Cushion padding

Backrest

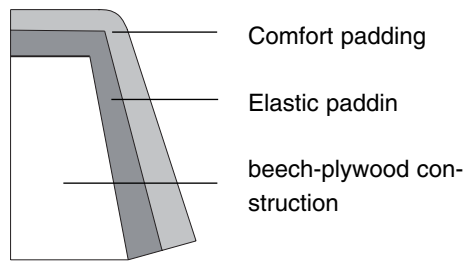

With fell seam

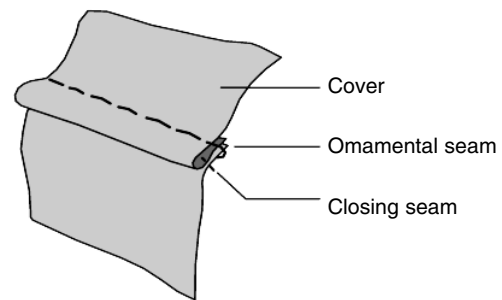

Seat cushion

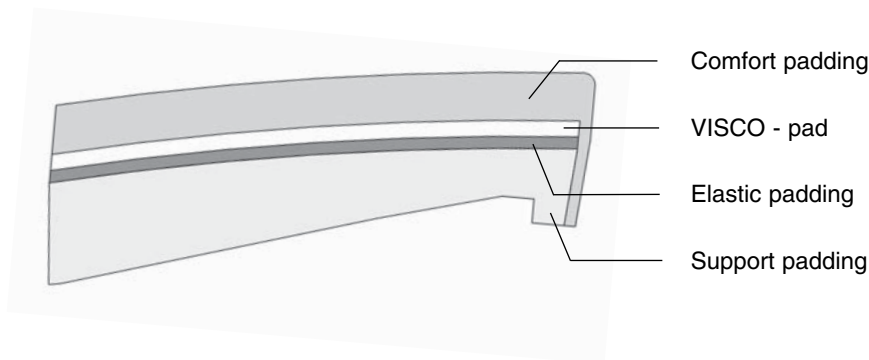

We do not process velours.

We use comfort Bultex in different strengths and weights by volume for our high-quality padding. They exceed RAL requirements by far.

Environmental balance

Frame: The steel construction and the beech-plywood construction is untreated.

Padding: The polyurethane foam used is produced with water vapour and is CFC-free.

Adhesives: Most of the adhesives are water-based products. For complex bonds, we now use adhesives containing reduced amounts of solvent.

Mechanical design: The mechanism is screwed together and can be separated. It has a solvent-free KTL varnish.

Leather covers: The dyes in our shagreen are free from solvent on completion of the production process. Since 1985, FSM has processed leather with reduced chrome content which is free from solvents. This exceeds German environmental standards.